

DTI 7000

Fast. Efficient. Accurate. Affordable.

Automatic Feed Brass Head Nail Gun.

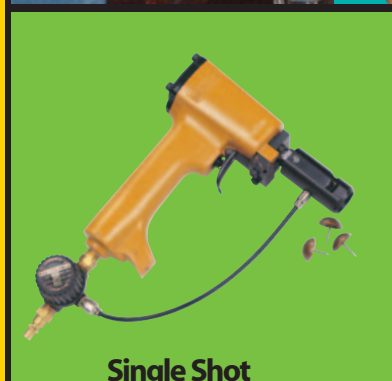

DTI

DTI DESIGN
TOOL
INC.

Automatic Feed Brass Head Nail Gun.

DTI

SPECIAL FEATURES

- Easy to maneuver, very accurate
- Light-weight, reduces operator fatigue
- Unique barrel design will drive nail straight every time
- Barrel designed to drive in any direction
- Gun will not damage tacks or harm fabric cloth, leather, vinyl, etc.
- Adjustable driving power for varying hardness of frame material
- Machine will not waste brass head nails
- Operator can drive a minimum of 100 decorative nails per minute
- Speeds production—one upholsterer can do the work of four
- Modifications can be made to accommodate various size brass head nails
- Minimum maintenance

SPECIFICATIONS

APPLICATION

Attaching brass head decorative nails to upholstery furniture

FASTENERS

Standard brass head decorative nails—various lengths

BASE UNIT ASSEMBLY

Weight: approx. 50 lbs.
Width: 12 inches
Length: 18 inches
Height: 8 3/4 inches

FEEDER BOWL

Diameter: 10 inches
Capacity: approx. 2500 nails

DRIVER UNIT ASSEMBLY

Weight: approx. 3 3/4 lbs.
Easy Trigger Pull

ELECTRICAL SUPPLY

110 volts (electricity only required to operate feeder bowl)

AIR SUPPLY

Air Pressure: 45 to 55 PSI
(determined by hardness of material)
Air Filtration: 50 micron
Hose Size: 1/4 I.D.

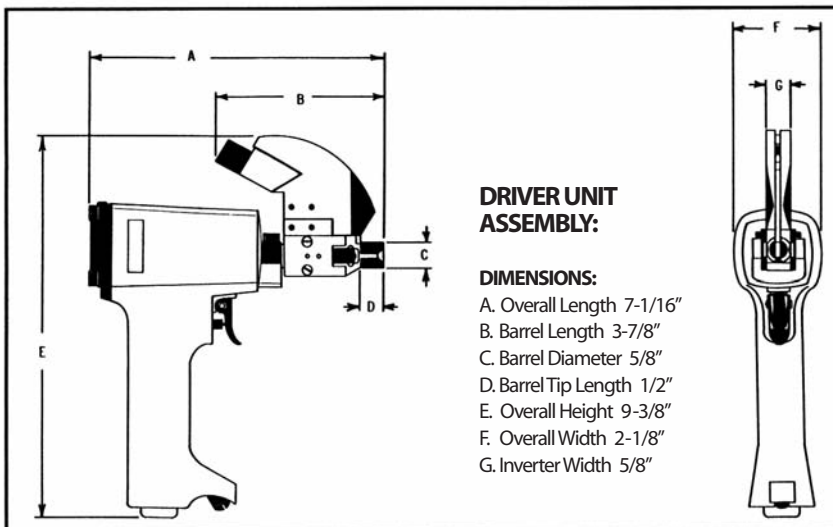

1607 NORFOLK PLACE SW • CONOVER, NC 28613
800 948 1038 828 328 4127 fax
designtoolinc.com • sales@designtoolinc.com